

Features STSBL-3

Gantry Types: SBL500 / SBL1000 / SBL1100

Self Weight: 1192 kg (2628 lbs)

A-A (1:10)

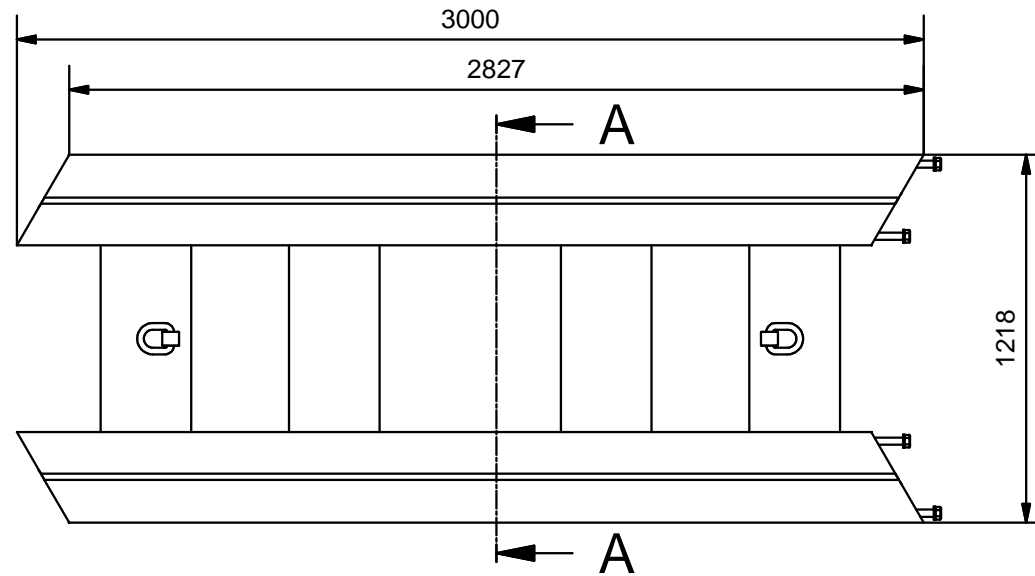
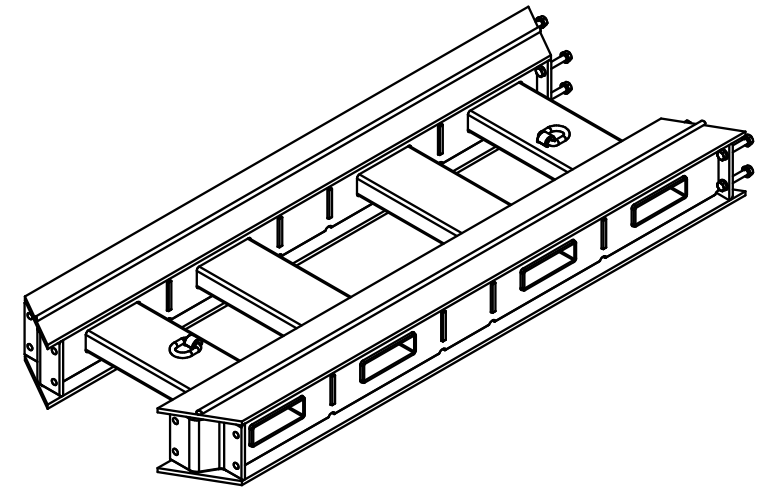
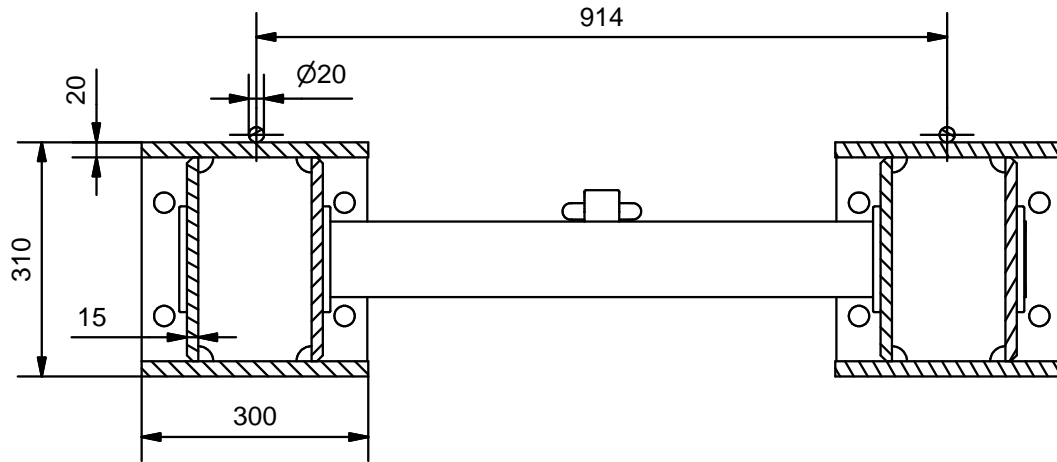

OPAALSTRAAT 44, 7554 TS HENGELO HOLLAND
PO BOX 421, 7550 AK HENGELO HOLLAND
TELEPHONE 074-2422045 FACSIMILE 074-2430338

ENERPAC
COPYRIGHTS RESERVED

3rd ANGLE
PROJECTION

Model Number:

STSBL-3

Main Assembly Number:

03134.01.03.00

Drawing Number:

03134.50.03.00

REV.:
0

DATE:
31-10-2013

SCALE:
1:25

FORM:
A4